



Premium performance



High load capacity



Extreme temperatures



Start-stop battery with state-of-the-art AGM technology

The powerful Continental Absorbent Glass Mat (AGM) battery is the right solution for complex start-stop systems with braking energy recovery.

It guarantees a life of at least three times more cycles compared with a conventional battery. Thanks to its high load capacity, it is able to absorb large overvoltages from braking operations, making energy recovery possible.

All the advantages at a glance

- > Ideal for vehicles with start-stop system and braking energy recovery (recuperation)
- > For demanding climatic and weather conditions: 135% Cold Cranking Amps (CCA)*
- > Long life of at least three times more cycles*
- > Very high deep-discharge capability
- > 20% less energy consumption and greenhouse emissions*
- > Extreme safety: 100% leak-proof
- > Maintenance-free - saves labor and costs
- > Two-year warranty

*Compared with conventional batteries.

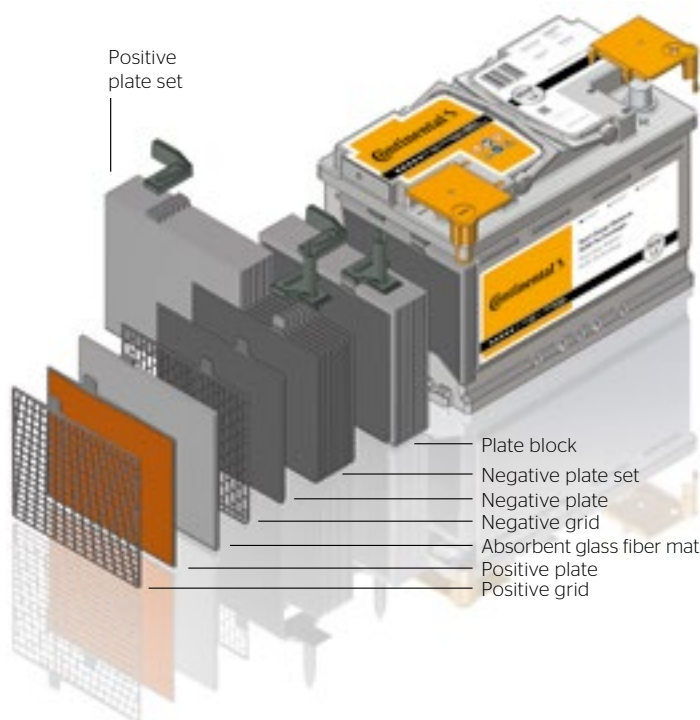

AGM technology: battery construction

Technical information

Article number	Type	Box	Dimensions (LxBxH) (mm)	Weight (kg)	Voltage (V)	Capacity (Ah)	Cold test current (A)	Polarity	Base plate	Circuit
2800012055280	AGM	L2	241 x 175 x 190	18.25	12	60	680	1	B13	0
2800012006280	AGM	L3	278 x 175 x 190	21.04	12	70	720	1	B13	0
2800012007280	AGM	L4	315 x 175 x 190	23.80	12	80	800	1	B13	0
2800012008280	AGM	L5	353 x 175 x 190	26.69	12	92	850	1	B13	0

Technical details

Pole type

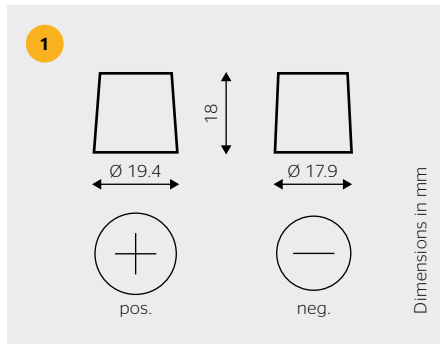

Base plate design

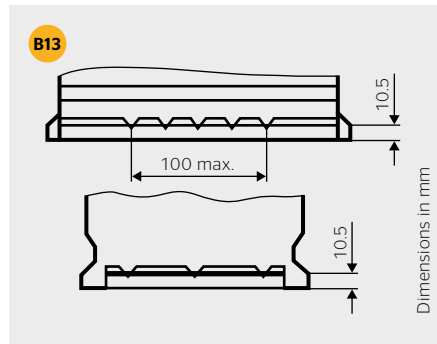

Pole arrangement

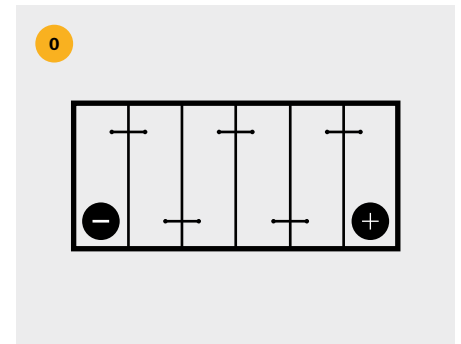

Ordering information

Article number	Product description	EAN number	No. of/pallet	Weight (kg)/pallet	Packing unit
2800012055280	Start-stop battery AGM L2 60/680	4103590777065	48	905	1
2800012006280	Start-stop battery AGM L3 70/720	4103590680372	60	798	1
2800012007280	Start-stop battery AGM L4 80/800	4103590680389	60	874	1
2800012008280	Start-stop battery AGM L5 92/850	4103590680396	60	842	1

Continental batteries compared



Criteria	EFB battery	AGM battery	Starter battery
Vehicle type	Start-stop	Start-stop and recuperation	Without start-stop (gasoline/diesel vehicles)
Cycle stability	>> 200%*	>> 300%*	100%
Technology	EFB - Enhanced Flooded Battery	AGM - Absorbent Glass Mat	Lead acid
Maintenance	Maintenance-free	Maintenance-free	Low maintenance
Number of battery types	8	4	22
Cold start capacity	115%*	135%*	100%
Specification	OE-equivalent	OE-equivalent	OE-equivalent
Quality level	OEM quality	OEM quality	OEM quality
Suitable for recuperation	-	Yes	-
Deep discharge	Good	Very good	-
Vibration protection	Good	Very good	-
Charge acceptance	Good	Very good	-
Charge monitoring indicator (Magic Eye)	Yes	-	Yes
Leakproof	-	Yes	Yes
Warranty	2 years	2 years	2 years

*Compared with conventional batteries.



Continental Aftermarket & Services GmbH
 Sodener Straße 9 · 65824 Schwalbach · Germany
 Tel.: +49 6196 87-0
 info@continental-aftermarket.com
 www.continental-aftermarket.com